

Plasma Current, Position and Shape Control

June 2, 2010

June 2, 2010 - ITER International Summer School 2010

G. De Tommasi¹
in collaboration with
CREATE and EFDA-JET PPCC contributors
¹CREATE, Università di Napoli Federico II

Plasma magnetic
control

G. De Tommasi



Outline

Introduction

Plasma Magnetic
Modeling

Plasma Vertical
Stabilization
Problem

Plasma Shape
Control Problem

Plasma Current
Control problem

Plasma Position
and Shape Control
at JET

XSC
VS

Plasma Position
and Shape Control
at ITER

References



Introduction

Plasma Magnetic Modeling

Plasma Vertical Stabilization Problem

Plasma Shape Control Problem

Plasma Current Control problem

Plasma Position and Shape Control at JET

eXtreme Shape Controller

Vertical Stabilization System

Plasma Position and Shape Control at ITER

Outline

Introduction

Plasma Magnetic
Modeling

Plasma Vertical
Stabilization
Problem

Plasma Shape
Control Problem

Plasma Current
Control problem

Plasma Position
and Shape Control
at JET

XSC
VS

Plasma Position
and Shape Control
at ITER

References



- ▶ Plasma control is the crucial issue to be addressed in order to achieve the high performances envisaged for future tokamak devices
- ▶ High performance in tokamaks is achieved by plasmas with elongated poloidal cross section, which are vertically unstable
- ▶ Plasma magnetic **axisymmetric** control (shape and position) is an essential feature of all tokamaks
- ▶ If high performance and robustness are required, then a model-based design approach is needed

This lecture

1. focuses on plasma shape control and the vertical stabilization problems
2. presents the eXtreme Shape Controller (XSC) and the new Vertical Stabilization System (VS) recently deployed at the JET tokamak
3. briefly introduces a plasma position and shape control approach proposed for the ITER tokamak

Outline

Introduction

Plasma Magnetic
Modeling

Plasma Vertical
Stabilization
Problem

Plasma Shape
Control Problem

Plasma Current
Control problem

Plasma Position
and Shape Control
at JET

XSC
VS

Plasma Position
and Shape Control
at ITER

References

1. The plasma/circuits system is axisymmetric
2. The inertial effects can be neglected at the time scale of interest, since plasma mass density is low
3. The magnetic permeability μ is homogeneous, and equal to μ_0 everywhere

Mass vs Massless plasma

Recently, it has been proven that neglecting plasma mass may lead to erroneous conclusion on closed-loop stability.

 M. L. Walker and D. A. Humphreys,
A multivariable analysis of the plasma vertical instability in tokamaks
Proc. 45th Conf. Decision Control, San Diego, CA, Dec. 2006, pp. 2213–2219





The *input variables* are:

- ▶ The voltage applied to the active coils v
- ▶ The plasma current I_p
- ▶ The poloidal beta β_p
- ▶ The internal inductance I_i

I_p , β_p and I_i

I_p , β_p and I_i are used to specify the current density distribution inside the plasma region.

Outline

Introduction

Plasma Magnetic
Modeling

Plasma Vertical
Stabilization
Problem

Plasma Shape
Control Problem

Plasma Current
Control problem

Plasma Position
and Shape Control
at JET

XSC
VS

Plasma Position
and Shape Control
at ITER

References



Different model outputs can be chosen:

- ▶ fluxes and fields where the magnetic sensors are located
- ▶ currents in the active and passive circuits
- ▶ plasma radial and vertical position (1st and 2nd moment of the plasma current density)
- ▶ geometrical descriptors describing the plasma shape (gaps, x-point and strike points positions)

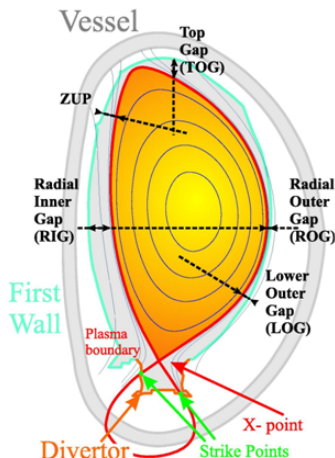

Outline

Introduction

Plasma Magnetic Modeling

Plasma Vertical Stabilization Problem

Plasma Shape Control Problem

Plasma Current Control problem

Plasma Position and Shape Control at JET

XSC
VS

Plasma Position and Shape Control at ITER

References



By using finite-elements methods, **nonlinear** lumped parameters approximation of the PDEs model is obtained

$$\frac{d}{dt} \left[\mathcal{M}(\mathbf{y}(t), \beta_p(t), I_i(t)) \mathbf{I}(t) \right] + \mathbf{R} \mathbf{I}(t) = \mathbf{U}(t),$$
$$\mathbf{y}(t) = \mathcal{Y}(\mathbf{I}(t), \beta_p(t), I_i(t)).$$

where:

- ▶ $\mathbf{y}(t)$ are the output to be controlled
- ▶ $\mathbf{I}(t) = [\mathbf{I}_{PF}^T(t) \mathbf{I}_e^T(t) I_p(t)]^T$ is the currents vector, which includes the currents in the active coils $\mathbf{I}_{PF}(t)$, the eddy currents in the passive structures $\mathbf{I}_e(t)$, and the plasma current $I_p(t)$
- ▶ $\mathbf{U}(t) = [\mathbf{U}_{PF}^T(t) \mathbf{0}^T 0]^T$ is the input voltages vector
- ▶ $\mathcal{M}(\cdot)$ is the mutual inductance nonlinear function
- ▶ \mathbf{R} is the resistance matrix
- ▶ $\mathcal{Y}(\cdot)$ is the output nonlinear function

Outline

Introduction

Plasma Magnetic Modeling

Plasma Vertical Stabilization Problem

Plasma Shape Control Problem

Plasma Current Control problem

Plasma Position and Shape Control at JET

XSC
VS

Plasma Position and Shape Control at ITER

References



Starting from the nonlinear lumped parameters model, the following plasma linearized state space model can be easily obtained:

$$\delta\dot{\mathbf{x}}(t) = \mathbf{A}\delta\mathbf{x}(t) + \mathbf{B}\delta\mathbf{u}(t) + \mathbf{E}\delta\dot{\mathbf{w}}(t), \quad (1)$$

$$\delta\mathbf{y}(t) = \mathbf{C} \delta\mathbf{l}_{PF}(t) + \mathbf{F}\delta\mathbf{w}(t), \quad (2)$$

where:

- ▶ **A**, **B**, **E**, **C** and **F** are the model matrices
- ▶ $\delta\mathbf{x}(t) = [\delta\mathbf{l}_{PF}^T(t) \delta\mathbf{l}_e^T(t) \delta l_p(t)]^T$ is the state space vector
- ▶ $\delta\mathbf{u}(t) = [\delta\mathbf{U}_{PF}^T(t) \mathbf{0}^T \mathbf{0}]^T$ are the input voltages variations
- ▶ $\delta\mathbf{w}(t) = [\delta\beta_p(t) \delta l_i(t)]^T$ are the β_p and l_i variations
- ▶ $\delta\mathbf{y}(t)$ are the output variations

The model (1)–(2) relates the variations of the PF currents to the variations of the outputs around a given equilibrium

Outline

Introduction

Plasma Magnetic Modeling

Plasma Vertical Stabilization Problem

Plasma Shape Control Problem

Plasma Current Control problem

Plasma Position and Shape Control at JET

XSC vs

Plasma Position and Shape Control at ITER

References



Objectives

- ▶ Vertically stabilize elongated plasmas in order to avoid disruptions
- ▶ Counteract the effect of disturbances (ELMs, fast disturbances modelled as VDEs,...)
- ▶ It does not control vertical position but it *simply* stabilizes the plasma
- ▶ **The VS is the essential magnetic control system!**

Outline

Introduction

Plasma Magnetic
Modeling

Plasma Vertical
Stabilization
Problem

Plasma Shape
Control Problem

Plasma Current
Control problem

Plasma Position
and Shape Control
at JET

XSC
VS

Plasma Position
and Shape Control
at ITER

References



Simplified filamentary model

Consider the simplified electromechanical model with three conductive rings, two rings are kept fixed and in symmetric position with respect to the r axis, while the third can freely move vertically.

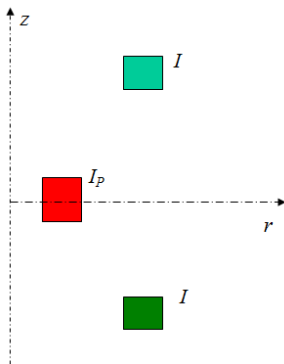

If the currents in the two fixed rings are equal, the vertical position $z = 0$ is an equilibrium point for the system.

Outline

Introduction

Plasma Magnetic Modeling

Plasma Vertical Stabilization Problem

Plasma Shape Control Problem

Plasma Current Control problem

Plasma Position and Shape Control at JET

XSC VS

Plasma Position and Shape Control at ITER

References



If $\text{sgn}(I_p) \neq \text{sgn}(I)$

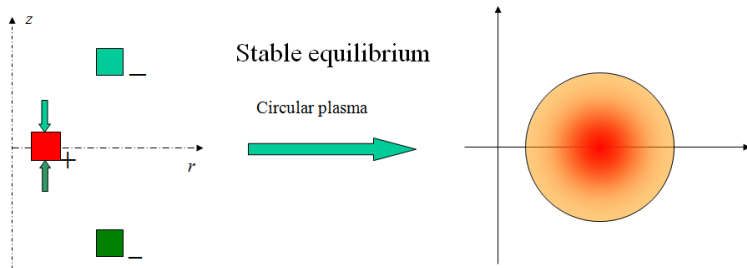

Outline

Introduction

Plasma Magnetic Modeling

Plasma Vertical Stabilization Problem

Plasma Shape Control Problem

Plasma Current Control problem

Plasma Position and Shape Control at JET

XSC
VS

Plasma Position and Shape Control at ITER

References



If $\text{sgn}(I_p) \neq \text{sgn}(I)$

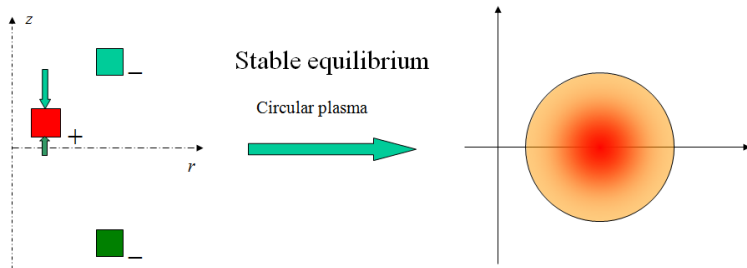

Outline

Introduction

Plasma Magnetic Modeling

Plasma Vertical Stabilization Problem

Plasma Shape Control Problem

Plasma Current Control problem

Plasma Position and Shape Control at JET

XSC
VS

Plasma Position and Shape Control at ITER

References



If $\text{sgn}(I_p) = \text{sgn}(I)$

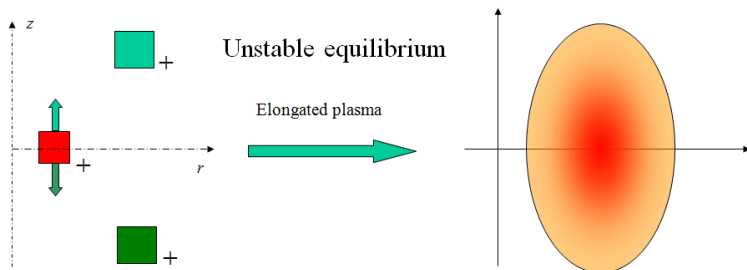

Outline

Introduction

Plasma Magnetic Modeling

Plasma Vertical Stabilization Problem

Plasma Shape Control Problem

Plasma Current Control problem

Plasma Position and Shape Control at JET

XSC
VS

Plasma Position and Shape Control at ITER

References



If $\text{sgn}(I_p) = \text{sgn}(I)$

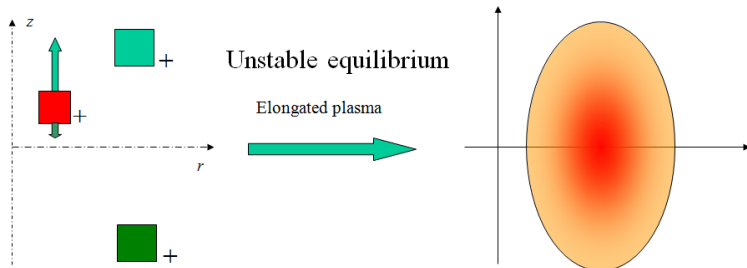

Outline

Introduction

Plasma Magnetic Modeling

Plasma Vertical Stabilization Problem

Plasma Shape Control Problem

Plasma Current Control problem

Plasma Position and Shape Control at JET

XSC
VS

Plasma Position and Shape Control at ITER

References



- ▶ The plasma vertical instability reveals itself in the linearized model, by the presence of an unstable eigenvalue in the dynamic system matrix
- ▶ The vertical instability growth time is slowed down by the presence of the conducting structure surrounding the plasma
- ▶ This allows to use a feedback control system to stabilize the plasma equilibrium, using for example a pair of dedicated coils
- ▶ This feedback loop usually acts on a faster time-scale than the plasma shape control loop

Outline

Introduction

Plasma Magnetic
Modeling

Plasma Vertical
Stabilization
Problem

Plasma Shape
Control Problem

Plasma Current
Control problem

Plasma Position
and Shape Control
at JET

XSC
VS

Plasma Position
and Shape Control
at ITER

References

Vertical Stabilization system

- ▶ single/multiple actuators (RFA @ JET, VS1, VS2, in-vessel coils @ ITER)
- ▶ drive the voltages into the actuators
- ▶ vertical position plasma stabilization + control of current into the actuators

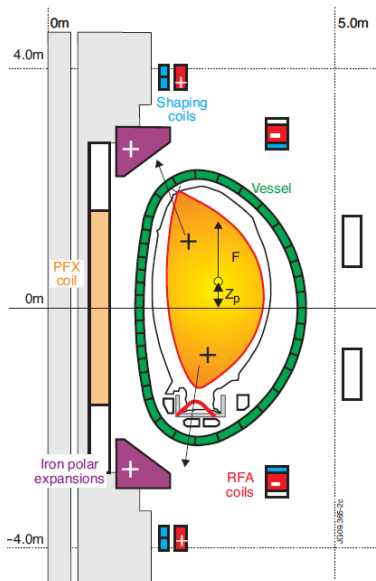

Plasma magnetic control

G. De Tommasi



Outline

Introduction

Plasma Magnetic Modeling

Plasma Vertical Stabilization Problem

Plasma Shape Control Problem

Plasma Current Control problem

Plasma Position and Shape Control at JET

XSC
VS

Plasma Position and Shape Control at ITER

References



- ▶ The problem of controlling the plasma shape is probably the most understood and mature of all the control problems in a tokamak
- ▶ The actuators are the Poloidal Field coils, that produce the magnetic field acting on the plasma
- ▶ The controlled variables are a finite number of geometrical descriptors chosen to describe the plasma shape

Objectives

- ▶ Precise control of plasma boundary
- ▶ Counteract the effect of disturbances (β_p and I_i variations)
- ▶ Manage saturation of the actuators (currents in the PF coils)

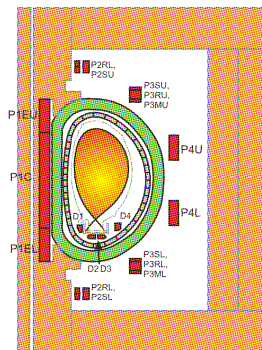

Outline

Introduction

Plasma Magnetic Modeling

Plasma Vertical Stabilization Problem

Plasma Shape Control Problem

Plasma Current Control problem

Plasma Position and Shape Control at JET

XSC
VS

Plasma Position and Shape Control at ITER

References

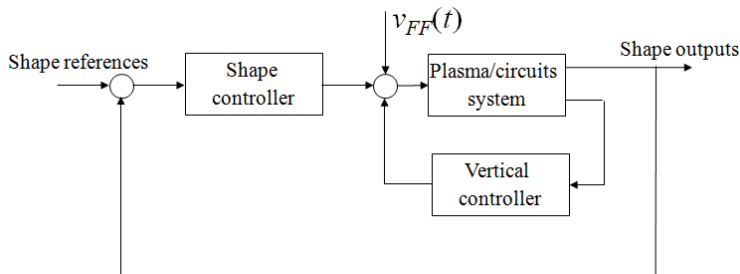

- ▶ $v_{FF}(t)$ are the *scenario* voltages feeded in feed-forward to the plant
- ▶ Both the VS and the SC generate input voltage variations.

Outline

Introduction

Plasma Magnetic Modeling

Plasma Vertical Stabilization Problem

Plasma Shape Control Problem

Plasma Current Control problem

Plasma Position and Shape Control at JET

XSC
VS

Plasma Position and Shape Control at ITER

References

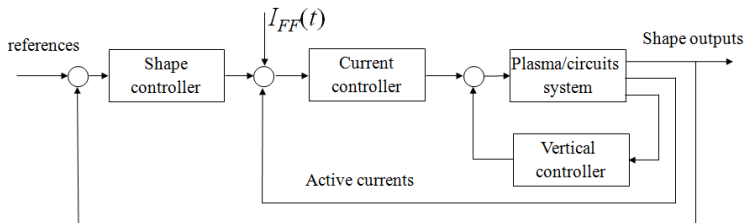

- ▶ The scenario is usually specified in terms of feed-forward currents $I_{FF}(t)$.
- ▶ It is convenient that the SC generates current references
- ▶ A PF currents controller must be designed

Outline

Introduction

Plasma Magnetic Modeling

Plasma Vertical Stabilization Problem

Plasma Shape Control Problem

Plasma Current Control problem

Plasma Position and Shape Control at JET

XSC
VS

Plasma Position and Shape Control at ITER

References



It is important to note that plasma shape control and vertical stabilization can be performed on different time scales.

Examples

ITER the time constant of the unstable mode in the ITER tokamak is about 100 *ms*, the settling time of the SC can vary between 15 and 25 *s*.

JET the time constant of the unstable mode in the JET tokamak is about 2 *ms*, the settling time of the SC is about 0.7 *s*.

Outline

Introduction

Plasma Magnetic Modeling

Plasma Vertical Stabilization Problem

Plasma Shape Control Problem

Plasma Current Control problem

Plasma Position and Shape Control at JET

XSC
VS

Plasma Position and Shape Control at ITER

References

- ▶ Plasma current can be controlled by using the current in the PF coils
- ▶ Since there is a sharing of the actuators, the problem of tracking the plasma current is often considered simultaneously with the shape control problem
- ▶ The PF coils have to generate a magnetic flux in order to drive ohmic current into the plasma
- ▶ Shape control and plasma current control are compatible, since it is possible to show that generating flux that is spatially uniform across the plasma (but with a desired temporal behavior) can be used to drive the current without affecting the plasma shape.





At the JET tokamak:

- ▶ Two different shape controllers are available
 - ▶ the *standard* Shape Controller (SC). This controller can be set in *full current control mode* (acting as a PF currents controller)
 - ▶ the eXtreme Shape Controller (XSC)
- ▶ The vertical stabilization controller, whose gains are *adaptively* changed during the discharge

Outline

Introduction

Plasma Magnetic
Modeling

Plasma Vertical
Stabilization
Problem

Plasma Shape
Control Problem

Plasma Current
Control problem

Plasma Position
and Shape Control
at JET

XSC
VS

Plasma Position
and Shape Control
at ITER

References

JET Shape Controller - Controller Scheme

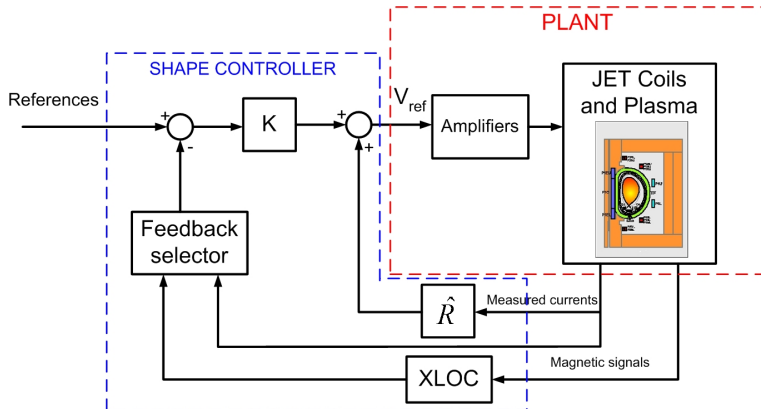

Plasma magnetic control

G. De Tommasi



Outline

Introduction

Plasma Magnetic Modeling

Plasma Vertical Stabilization Problem

Plasma Shape Control Problem

Plasma Current Control problem

Plasma Position and Shape Control at JET

XSC
VS

Plasma Position and Shape Control at ITER

References



Plasmaless model

$$\mathbf{V}_{PF} = \begin{bmatrix} L_1 & M_{12} & \dots & M_{1N} \\ M_{12} & L_2 & \dots & M_{2N} \\ \dots & \dots & \dots & \dots \\ M_{1N} & M_{2N} & \dots & L_N \end{bmatrix} \frac{d\mathbf{I}_{PF}}{dt} + \begin{bmatrix} R_1 & 0 & \dots & 0 \\ 0 & R_2 & 0 & 0 \\ \dots & \dots & \dots & \dots \\ 0 & 0 & \dots & R_N \end{bmatrix} \mathbf{I}_{PF}$$

Resistive compensation

$$\mathbf{V}_{PF_{ref}} = \hat{\mathbf{R}}\mathbf{I}_{PF} + \mathbf{K}(\mathbf{Y}_{ref} - \mathbf{Y})$$

Static relationship between PF coils current and controlled variables

$$\mathbf{Y} = \mathbf{T}\mathbf{I}_{PF}$$

Control Matrix

$$\mathbf{K} = \hat{\mathbf{M}}\mathbf{T}^{-1}\mathbf{\Lambda}^{-1} \text{ with } \mathbf{\Lambda} \text{ diagonal matrix}$$

Outline

Introduction

Plasma Magnetic Modeling

Plasma Vertical Stabilization Problem

Plasma Shape Control Problem

Plasma Current Control problem

Plasma Position and Shape Control at JET

XSC
VS

Plasma Position and Shape Control at ITER

References



Closed-loop system

$$\begin{aligned} \mathbf{MT}^{-1}\dot{\mathbf{Y}} + \mathbf{RI}_{PF} &= \mathbf{MT}^{-1}\Lambda^{-1}(\mathbf{Y}_{ref} - \mathbf{Y}) + \mathbf{RI}_{PF} \Rightarrow \\ \Rightarrow \dot{\mathbf{Y}} &= \Lambda^{-1}(\mathbf{Y}_{ref} - \mathbf{Y}) \end{aligned}$$

By a proper choice of the \mathbf{T} matrix it is possible to achieve:

- ▶ current control mode
- ▶ plasma current control mode
- ▶ gap control mode



F. Sartori, G. De Tommasi, F. Piccolo

The Joint European Torus

IEEE Control Systems Magazine, April 2006

Outline

Introduction

Plasma Magnetic
Modeling

Plasma Vertical
Stabilization
Problem

Plasma Shape
Control Problem

Plasma Current
Control problem

Plasma Position
and Shape Control
at JET

XSC
VS

Plasma Position
and Shape Control
at ITER

References



- ▶ Each circuit is used to control a single variable (current, gap, flux)
- ▶ Up to 9 different variables can be controlled
- ▶ Since plasma current is always controlled, up to 8 gaps can be controlled

Outline

Introduction

Plasma Magnetic
Modeling

Plasma Vertical
Stabilization
Problem

Plasma Shape
Control Problem

Plasma Current
Control problem

Plasma Position
and Shape Control
at JET

XSC
VS

Plasma Position
and Shape Control
at ITER

References

- ▶ To control the plasma shape in JET, in principle 8 *knobs* are available, namely the currents in the PF circuits except *P1* which is used only to control the plasma current
- ▶ As a matter of fact, these 8 knobs do not practically guarantee 8 degrees of freedom to change the plasma shape
- ▶ Indeed there are 2 or 3 current combinations that cause small effects on the shape (depending on the considered equilibrium).
- ▶ **The design of the XSC is model-based. Different controller gains must be designed for each different plasma equilibrium, in order to achieve the desired performances**





SC in current control mode

The XSC exploits the standard JET Shape Controller architecture. In particular it sets:

- ▶ the P1 circuit in *plasma current control mode*
- ▶ the other 8 PF circuits in *current control mode*

Model of the current controlled plant

$$\delta \mathbf{g}(s) = \frac{\tilde{\mathbf{C}}}{1 + s\tau} \cdot \frac{\delta \mathbf{l}_{PF_{REF}}(s)}{I_P}$$

Outline

Introduction

Plasma Magnetic
Modeling

Plasma Vertical
Stabilization
Problem

Plasma Shape
Control Problem

Plasma Current
Control problem

Plasma Position
and Shape Control
at JET

XSC
vs

Plasma Position
and Shape Control
at ITER

References

XSC - Controller scheme

Plasma magnetic control

G. De Tommasi

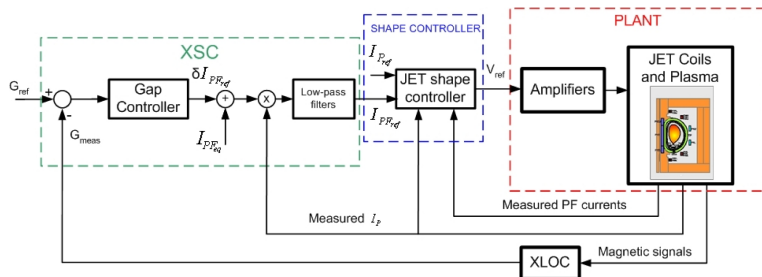

Outline

Introduction

Plasma Magnetic Modeling

Plasma Vertical Stabilization Problem

Plasma Shape Control Problem

Plasma Current Control problem

Plasma Position and Shape Control at JET

XSC vs

Plasma Position and Shape Control at ITER

References



- ▶ The *eXtreme Shape Controller (XSC)* controls the whole plasma shape, specified as a set of **32** geometrical descriptors, calculating the PF coil current references.
- ▶ Let $\mathbf{I}_{PF_N}(t)$ be the PF currents normalized to the equilibrium plasma current, it is

$$\delta \mathbf{g}(t) = \mathbf{C} \delta \mathbf{I}_{PF_N}(t).$$

It follows that the plasma boundary descriptors have the same dynamic response of the PF currents.

- ▶ The XSC design has been based on the \mathbf{C} matrix. Since the number of independent control variables is less than the number of outputs to regulate, it is not possible to track a generic set of references with zero steady-state error.

$$\delta \mathbf{I}_{PF_{Nreq}} = \mathbf{C}^\dagger \delta \mathbf{g}_{error}$$

Outline

Introduction

Plasma Magnetic Modeling

Plasma Vertical Stabilization Problem

Plasma Shape Control Problem

Plasma Current Control problem

Plasma Position and Shape Control at JET

XSC vs

Plasma Position and Shape Control at ITER

References



- ▶ The XSC has then been implemented introducing weight matrices both for the geometrical descriptors and for the PF coil currents.
- ▶ The determination of the controller gains is based on the Singular Value Decomposition (SVD) of the following weighted output matrix:

$$\tilde{\mathbf{C}} = \tilde{\mathbf{Q}} \mathbf{C} \tilde{\mathbf{R}}^{-1} = \tilde{\mathbf{U}} \tilde{\mathbf{S}} \tilde{\mathbf{V}}^T,$$

where $\tilde{\mathbf{Q}}$ and $\tilde{\mathbf{R}}$ are two diagonal matrices.

- ▶ The XSC minimizes the cost function

$$\tilde{J}_1 = \lim_{t \rightarrow +\infty} (\delta \mathbf{g}_{ref} - \delta \mathbf{g}(t))^T \tilde{\mathbf{Q}}^T \tilde{\mathbf{Q}} (\delta \mathbf{g}_{ref} - \delta \mathbf{g}(t)),$$

using $\bar{n} < 8$ degrees of freedom, while the remaining $8 - \bar{n}$ degrees of freedom are exploited to minimize

$$\tilde{J}_2 = \lim_{t \rightarrow +\infty} \delta \mathbf{I}_{PFN}(t)^T \tilde{\mathbf{R}}^T \tilde{\mathbf{R}} \delta \mathbf{I}_{PFN}(t).$$

(it contributes to avoid PF current saturations)

Outline

Introduction

Plasma Magnetic
Modeling

Plasma Vertical
Stabilization
Problem

Plasma Shape
Control Problem

Plasma Current
Control problem

Plasma Position
and Shape Control
at JET

XSC
vs

Plasma Position
and Shape Control
at ITER

References

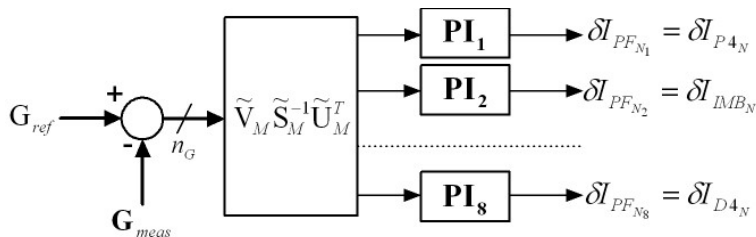

Outline

Introduction

Plasma Magnetic Modeling

Plasma Vertical Stabilization Problem

Plasma Shape Control Problem

Plasma Current Control problem

Plasma Position and Shape Control at JET

XSC vs

Plasma Position and Shape Control at ITER

References



SC

- ▶ A few geometric parameters are controlled, usually one gap (Radial Outer Gap, ROG) and two strike points
- ▶ The desired shape is achieved precalculating the needed currents and putting these currents as references to the SC
- ▶ This gives a good tracking of the references on ROG and on the strike points **but the shape cannot be guaranteed precisely**
- ▶ Shape modifications due to variations of β_p and I_i cannot be counteracted

XSC

- ▶ The shape to be achieved can be chosen
- ▶ The XSC receives the errors on 36 descriptors of the plasma shape and calculates the "smallest" currents needed to minimize the error on the "overall" shape
- ▶ The controller manages to keep the shape more or less constant even in the presence of large variations of β_p and I_i

Outline

Introduction

Plasma Magnetic Modeling

Plasma Vertical Stabilization Problem

Plasma Shape Control Problem

Plasma Current Control problem

Plasma Position and Shape Control at JET

XSC vs

Plasma Position and Shape Control at ITER

References



Outline

Introduction

Plasma Magnetic
Modeling

Plasma Vertical
Stabilization
Problem

Plasma Shape
Control Problem

Plasma Current
Control problem

Plasma Position
and Shape Control
at JET

XSC
vs

Plasma Position
and Shape Control
at ITER

References

JET VS Control Scheme

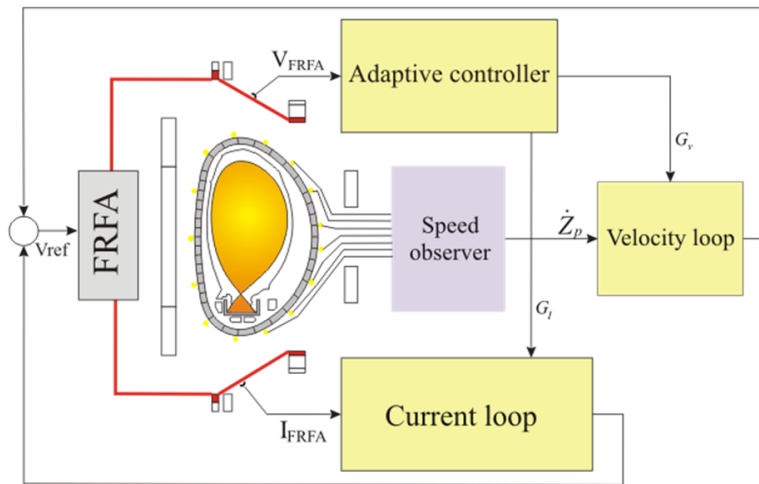

Plasma magnetic control

G. De Tommasi



Outline

Introduction

Plasma Magnetic Modeling

Plasma Vertical Stabilization Problem

Plasma Shape Control Problem

Plasma Current Control problem

Plasma Position and Shape Control at JET

xsc
vs

Plasma Position and Shape Control at ITER

References

Simplified control law

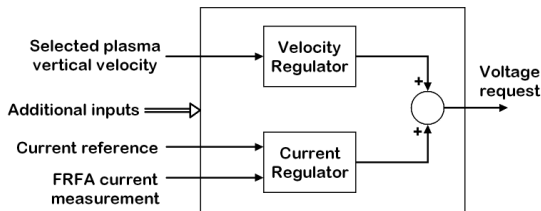

- ▶ proportional action on plasma velocity \dot{z}_p
- ▶ proportional-integral action on the current in the actuator

$$V_{req}(s) = G_v s Z_p(s) + G_I \left(1 + \frac{1}{T_I s}\right) (I_{ref}(s) - I(s))$$

where typically $I_{ref}(s) = 0$.

Adaptive gains

G_v and G_I are *adapted* during the discharge taking into account the power supply switching frequency, its temperature, the value of the current in the actuator,...





The **Plasma Control Upgrade (PCU)** project has increased the capabilities of the **JET VS** system so as to meet the requirements for future operations at JET (ITER-like wall, tritium campaign, ...).

The PCU project was aimed to enhance the ability of the VS system to recover from large ELMs, specially in the case of plasmas with large *growth rate*.

This is especially true for future operation at JET with the beryllium ITER-like wall.

Outline

Introduction

Plasma Magnetic
Modeling

Plasma Vertical
Stabilization
Problem

Plasma Shape
Control Problem

Plasma Current
Control problem

Plasma Position
and Shape Control
at JET

xsc
vs

Plasma Position
and Shape Control
at ITER

References



Within the PCU project, the design of the new VS system has included

1. the design of the new power supply for the RFA circuit
2. the assessment of the best choice for the number of turns for the coils of the RFA circuit
3. **the design of the new VS software, so as to deliver to the operator an high flexible architecture**

Outline

Introduction

Plasma Magnetic
Modeling

Plasma Vertical
Stabilization
Problem

Plasma Shape
Control Problem

Plasma Current
Control problem

Plasma Position
and Shape Control
at JET

xsc
vs

Plasma Position
and Shape Control
at ITER

References

Plasma position and shape control in the ITER using in-vessel coils

Plasma magnetic control

G. De Tommasi



Motivations

- ▶ During the *design review phase*, it turned out that the high-elongated and unstable plasmas needed for ITER operations can hardly be stabilized using the superconducting PF coils placed outside the tokamak vessel.
- ▶ It has been proposed to investigate the possibility of using in-vessel coils to improve the best achievable performance of the VS system.

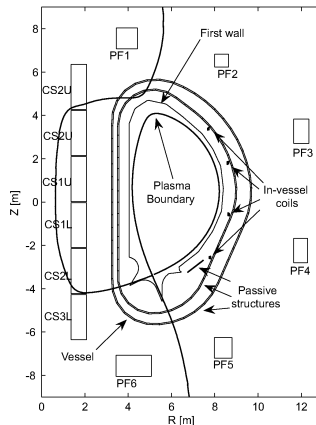

Outline

Introduction

Plasma Magnetic Modeling

Plasma Vertical Stabilization Problem

Plasma Shape Control Problem

Plasma Current Control problem

Plasma Position and Shape Control at JET

XSC
VS

Plasma Position and Shape Control at ITER

References

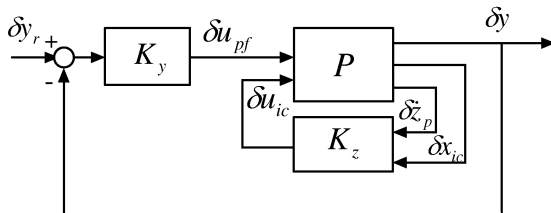

Two control loops are designed:

1. the VS system, which stabilizes the plasma vertical position;
2. the plasma current and shape control system, which drives the plasma current error to zero and minimizes the error between the actual plasma boundary and the desired shape reference.

Outline

Introduction

Plasma Magnetic Modeling

Plasma Vertical Stabilization Problem

Plasma Shape Control Problem

Plasma Current Control problem

Plasma Position and Shape Control at JET

XSC
VS

Plasma Position and Shape Control at ITER

References



Vertical stabilization controller with a simple structure is proposed, in order to envisage effective adaptive algorithms
Let the in-vessel $\delta u_{ic}(t)$ voltage be equal to

$$\delta U_{ic}(t) = k_D \delta \dot{z}_p(t) + k_I \delta I_{ic}(t)$$

Outline

Introduction

Plasma Magnetic
Modeling

Plasma Vertical
Stabilization
Problem

Plasma Shape
Control Problem

Plasma Current
Control problem

Plasma Position
and Shape Control
at JET

XSC
VS

Plasma Position
and Shape Control
at ITER

References

Design VS solving a BMI problem

Letting $\mathbf{k}^T = (k_D \quad k_I)$, the two gains k_D and k_I can be chosen so as to fix the closed-loop decay rate in the range $[\theta_{min}, \theta_{max}]$ by solving the following Bilinear Matrix Inequality (BMI)

$$(\mathbf{A} + \mathbf{b}\mathbf{k}^T\mathbf{C})^T\mathbf{P} + \mathbf{P}(\mathbf{A} + \mathbf{b}\mathbf{k}^T\mathbf{C}) < -2\theta\mathbf{P},$$

where \mathbf{P} is a symmetric positive definite matrix and

$$\mathbf{A} = -(\mathbf{L}^*)^{-1}\mathbf{R} \qquad \mathbf{b} = (\mathbf{L}^*)^{-1} \begin{pmatrix} \mathbf{0} \\ 1 \\ \mathbf{0} \end{pmatrix},$$
$$\mathbf{C} = \begin{pmatrix} \mathbf{c}_{1z}^T & c_{2z} & \mathbf{c}_{3z}^T \\ \mathbf{0} & 1 & \mathbf{0} \end{pmatrix} \begin{pmatrix} \mathbf{A} \\ \mathbf{I} \end{pmatrix},$$

with $\theta_{min} < \theta < \theta_{max}$, and $\theta_{min}, \theta_{max} > 0$.

The larger θ is, the faster the closed-loop system results.





Plasma current and shape control system can act on a slow time scale. It has been shown that the eddy current dynamics can be neglected in the design of the controller K_y . The plant model becomes

$$\delta \dot{\mathbf{i}}_{PF}(t) = (\mathbf{L}^*)^{-1} \delta \mathbf{U}_{PF}(t), \quad (3a)$$

$$\delta \mathbf{y}(t) = \mathbf{C} \delta \mathbf{i}_{PF}(t). \quad (3b)$$

The vector $\delta \mathbf{y}(t) = (\delta \mathbf{g}^T(t) \delta I_p(t))^T$ contains the plasma current plus a set of geometrical descriptors which completely characterize the plasma shape.

The matrix \mathbf{L}^* PF system inductance matrix modified by the presence of the VS loop.

Outline

Introduction

Plasma Magnetic Modeling

Plasma Vertical Stabilization Problem

Plasma Shape Control Problem

Plasma Current Control problem

Plasma Position and Shape Control at JET

XSC
VS

Plasma Position and Shape Control at ITER

References



If $\delta \mathbf{g}(t) = \mathbf{C}_g \delta \mathbf{l}_{PF}(t)$, let us consider the following singular value decomposition

$$\mathbf{C}_g = \mathbf{U}_g \mathbf{\Sigma}_g \mathbf{V}_g^T,$$

The control law is chosen as

$$\begin{aligned} \delta \mathbf{U}_{PF}(t) &= \mathbf{K}_{SF} \delta \mathbf{l}_{PF}(t) + \mathbf{K}_{P_1} \mathbf{V}_g \mathbf{\Sigma}_g^{-1} \mathbf{U}_g^T \delta \mathbf{g}(t) \\ &+ \mathbf{K}_{I_1} \mathbf{V}_g \mathbf{\Sigma}_g^{-1} \mathbf{U}_g^T \int_0^t (\delta \mathbf{g}(t) - \delta \mathbf{g}_r(t)) dt + k_{P_2} \delta I_p(t) + k_{I_2} \int_0^t (\delta I_p(t) - \delta I_{p_r}(t)) dt, \end{aligned}$$

where $\delta \mathbf{g}_r(t)$ and $\delta I_{p_r}(t)$ are the reference on the plasma geometrical descriptors and the plasma current.

Outline

Introduction

Plasma Magnetic Modeling

Plasma Vertical Stabilization Problem

Plasma Shape Control Problem

Plasma Current Control problem

Plasma Position and Shape Control at JET

XSC
VS

Plasma Position and Shape Control at ITER

References

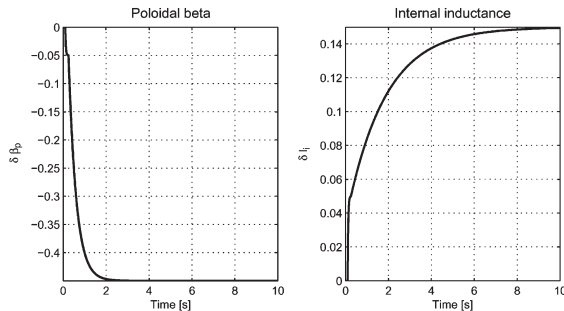

Figure: Analysis of the performance during an H-L transition. Time traces of $\delta\beta_p(t)$ and $\delta l_i(t)$.

Outline

Introduction

Plasma Magnetic Modeling

Plasma Vertical Stabilization Problem

Plasma Shape Control Problem

Plasma Current Control problem

Plasma Position and Shape Control at JET

XSC
VS

Plasma Position and Shape Control at ITER

References

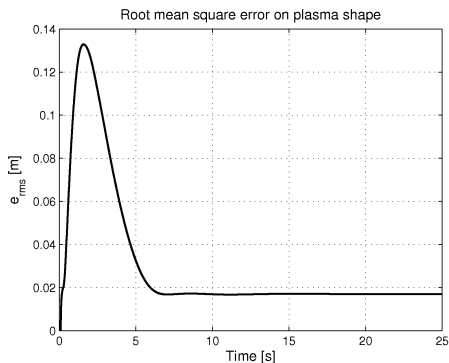

Figure: Analysis of the performance during an H-L transition. Mean square error on the controller plasma shape descriptors.

Outline

Introduction

Plasma Magnetic Modeling

Plasma Vertical Stabilization Problem

Plasma Shape Control Problem

Plasma Current Control problem

Plasma Position and Shape Control at JET

XSC
VS

Plasma Position and Shape Control at ITER

References

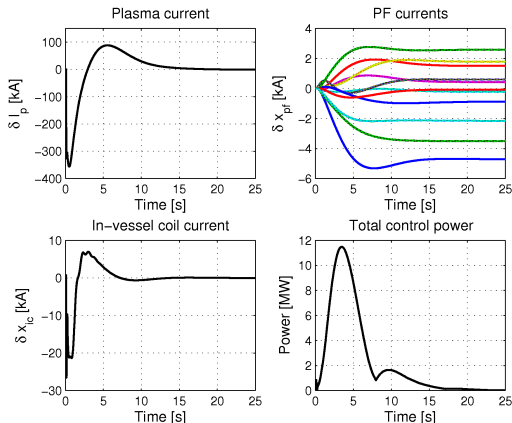

Figure: Analysis of the performance during an H-L transition. This figure shows the time traces of the plasma current variation $\delta I_p(t)$, of the control currents $\delta \mathbf{x}_{pf}(t)$, $\delta x_{ic}(t)$, and the total power required to track the desired shape reference.

Outline

Introduction

Plasma Magnetic Modeling

Plasma Vertical Stabilization Problem

Plasma Shape Control Problem

Plasma Current Control problem

Plasma Position and Shape Control at JET

XSC
VS

Plasma Position and Shape Control at ITER

References



An overview of the three basic magnetic control problems has been given:

- ▶ Vertical Stabilization
- ▶ Shape Control
- ▶ Plasma Current Control

...let's do practice in the lab!

THE END

Thank you!

Outline

Introduction

Plasma Magnetic
Modeling

Plasma Vertical
Stabilization
Problem

Plasma Shape
Control Problem

Plasma Current
Control problem

Plasma Position
and Shape Control
at JET



XSC
VS

Plasma Position
and Shape Control
at ITER

References



Plasma magnetic modelling

-  R. Albanese and G. Ambrosino
A survey on modeling and control of current, position and shape of axisymmetric plasmas
IEEE Control Systems Magazine, vol. 25, no. 5, pp. 76–91, Oct. 2005
-  M. Ariola and A. Pironti,
Magnetic Control of Tokamak Plasmas
Springer, 2008

Outline

Introduction

Plasma Magnetic
Modeling

Plasma Vertical
Stabilization
Problem

Plasma Shape
Control Problem

Plasma Current
Control problem

Plasma Position
and Shape Control
at JET





XSC
VS

Plasma Position
and Shape Control
at ITER

References



Plasma current position and shape control at JET

-  F. Sartori, G. De Tommasi and F. Piccolo
The Joint European Torus - Plasma position and shape control in the world's largest tokamak
IEEE Control Systems Magazine, vol. 26, no. 2, pp. 64-78, Apr. 2006
-  M. Ariola and A. Pironti
Plasma shape control for the JET tokamak
IEEE Control Systems Magazine vol. 25, no. 5, pp. 65-75, Oct. 2005
-  G. Ambrosino et al.
Design and Implementation of an Output Regulation Controller for the JET Tokamak
IEEE Transactions on Control Systems Technology, vol. 16, no. 6, pp. 1101-1111, Nov. 2008
-  G. De Tommasi et al.
XSC Tools: a software suite for tokamak plasma shape control design and validation
IEEE Transactions on Plasma Science, vol. 35, no. 3, pp. 709-723, Jun. 2007
-  F. Sartori et al.
The PCU JET Plasma Vertical Stabilization control system
Fusion Engineering and Design, accepted for publication, Jan. 2010

Outline

Introduction

Plasma Magnetic
Modeling

Plasma Vertical
Stabilization
Problem

Plasma Shape
Control Problem

Plasma Current
Control problem

Plasma Position
and Shape Control
at JET



XSC
VS

Plasma Position
and Shape Control
at ITER

References



Plasma shape and position control in ITER with in-vessel coils

-  G. Ambrosino et al.
Design of the plasma position and shape control in the ITER tokamak using in-vessel coils
IEEE Transactions on Plasma Science, vol. 37, no. 7, pp. 1324-1331, Jul. 2009.
-  G. Ambrosino et al.
Plasma Vertical Stabilization in the ITER Tokamak via Constrained Static Output Feedback
IEEE Transactions on Control Systems Technology, accepted for publication Feb. 2010.

Outline

Introduction

Plasma Magnetic Modeling

Plasma Vertical Stabilization Problem

Plasma Shape Control Problem

Plasma Current Control problem

Plasma Position and Shape Control at JET

XSC
VS

Plasma Position and Shape Control at ITER

References